

High Pressure Checkball Piston Pumps

PF6000 SERIES
12.7 to 54 gpm (48 to 204,4 L/min) at 1800 rpm
5 500 to 15 000 psi (380 to 1040 bar)

Fixed displacement checkball pumps, with bi-directional shaft rotation, provide constant direction of output flow regardless of the direction of drive shaft rotation.

Mounting

SAE E 4-bolt pattern with 0.25 inch (6,4 mm) pilot engagement

Shaft Options

Standard keyed shaft, 1.750 inch (44,45 mm) diameter;

Optional spline shaft, 1.748/1.747 inch diameter standard SAE 13 tooth, 8/16 DP 30° involute spline. Contact the Sales department for model number.

Outlet Port Options

Higher pressure models (PF6023, PF6033 and PF6046) require an outlet port block kit. Refer to page 3. Standard pressure models (PF6054, PF6070 and PF6080) have outlet ports with a pattern for standard 1 inch SAE 4-bolt flange.

Inlet Conditions

Pumps may require pressurized inlet conditions at higher speeds. Failure to meet minimum inlet requirements will result in slight flow reduction. Refer to the table on page 3.

Seal Options

Standard seals are Fluorocarbon (Viton® or Fluorel®) with high-pressure shaft seal. Contact the Sales department for other seal options.

Weight (Mass)

PF6023, PF6033 and PF6046:
240 lb (109 kg);

PF6054, PF6070 and PF6080:
330 lb (150 kg).



Specifications

Pump Models	Output Flow at 1500 rpm ^①		Output Flow at 1800 rpm ^①		Rated Pressure		Max. Pressure ^②		Speed rpm	
	U.S. gpm	L/min	U.S. gpm	L/min	psi	bar	psi	bar	Rated	Max.
<i>Outlet Block with Coned and Threaded Port:^③</i>										
PF6023-3167	10.5	40,0	12.7	48,0	15 000	1040	15 000	1040	1800	1800
<i>Outlet Block with SAE, Coned and Threaded, or BSPP Port:^{③④}</i>										
PF6033-3169	18.3	69,3	22.0	83,2	10 000	700	10 000	700	1800	1800
PF6046-3174	26.0	98,7	31.3	118,4	8000	560	8000	560	1800	1800
<i>Standard SAE 4-Bolt Flange Outlet Port:</i>										
PF6054-2946	29.5	111,6	35.4	134,0	6000	420	6000	420	1800	2400
PF6070-3186	39.6	150,1	47.6	180,1	6000	420	6000	420	1800	2300
PF6080-2989	45.0	170,3	54.0	204,4	5500	380	5500	380	1800	2200

^① Output flow based on typical performance at rated pressure with pressurized inlet where required, as shown in the table on page 3.

^② Contact the Sales department for applications requiring higher operating pressures.

^③ High pressure Coned and Threaded outlet port uses Autoclave Medium Pressure, Butech M/P or equivalent fitting. Refer to "Outlet Port Block Kits" on page 3.

^④ BSPP outlet port uses British Standard Pipe Parallel fitting. Refer to "Outlet Port Block Kits" on page 3.

PUMP SELECTION

The *Specifications Table* lists the most commonly used standard models with keyed shafts. Contact the Sales department for model numbers with spline shafts, optional seals and other extraordinary operating requirements.

Maximum Pressure

Checkball pumps are especially suited for applications susceptible to excessive pressure spikes.

The pressures listed are the maximum pressures a pump can sustain for occasional, short periods of operation without appreciably reducing life expectancy.

Typical Performance Curves

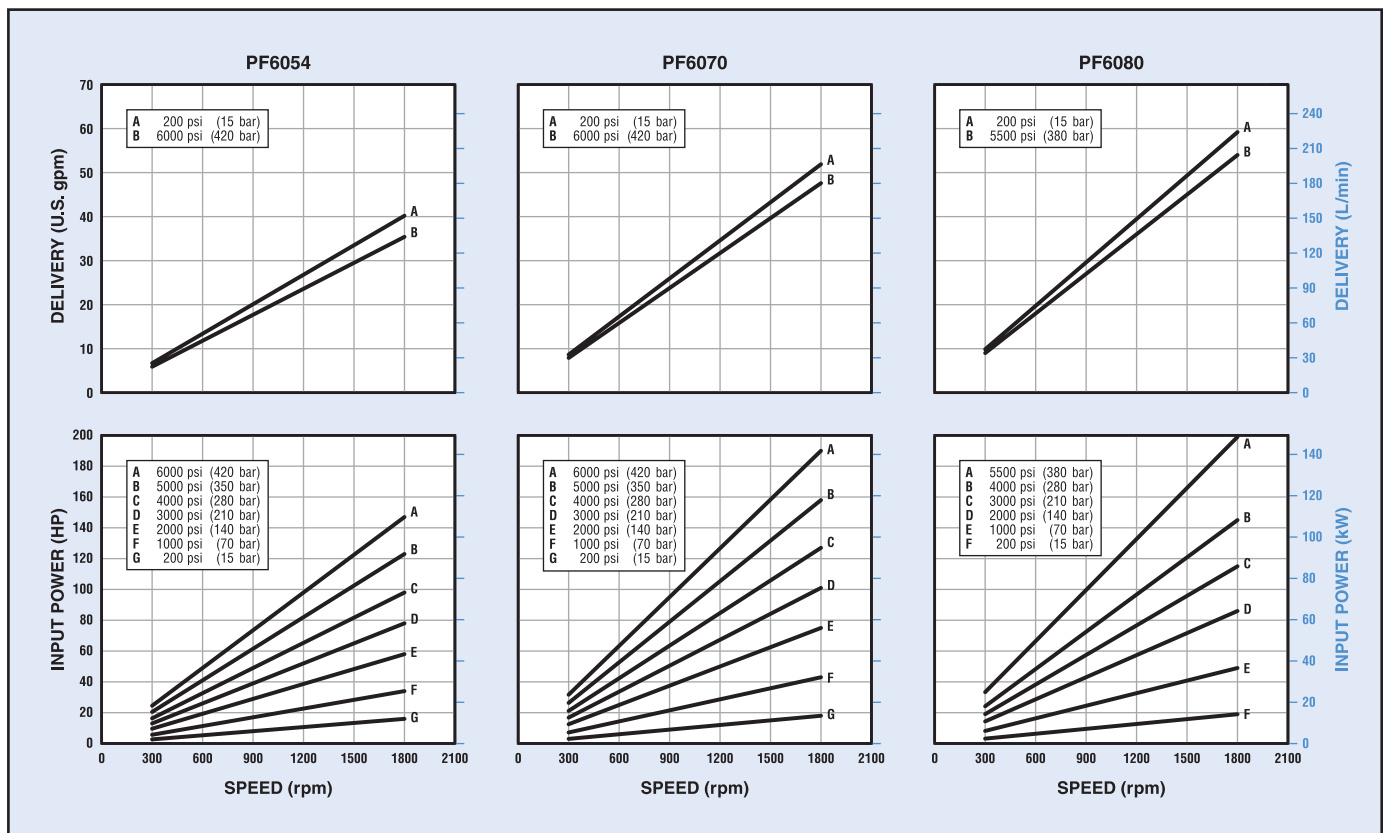
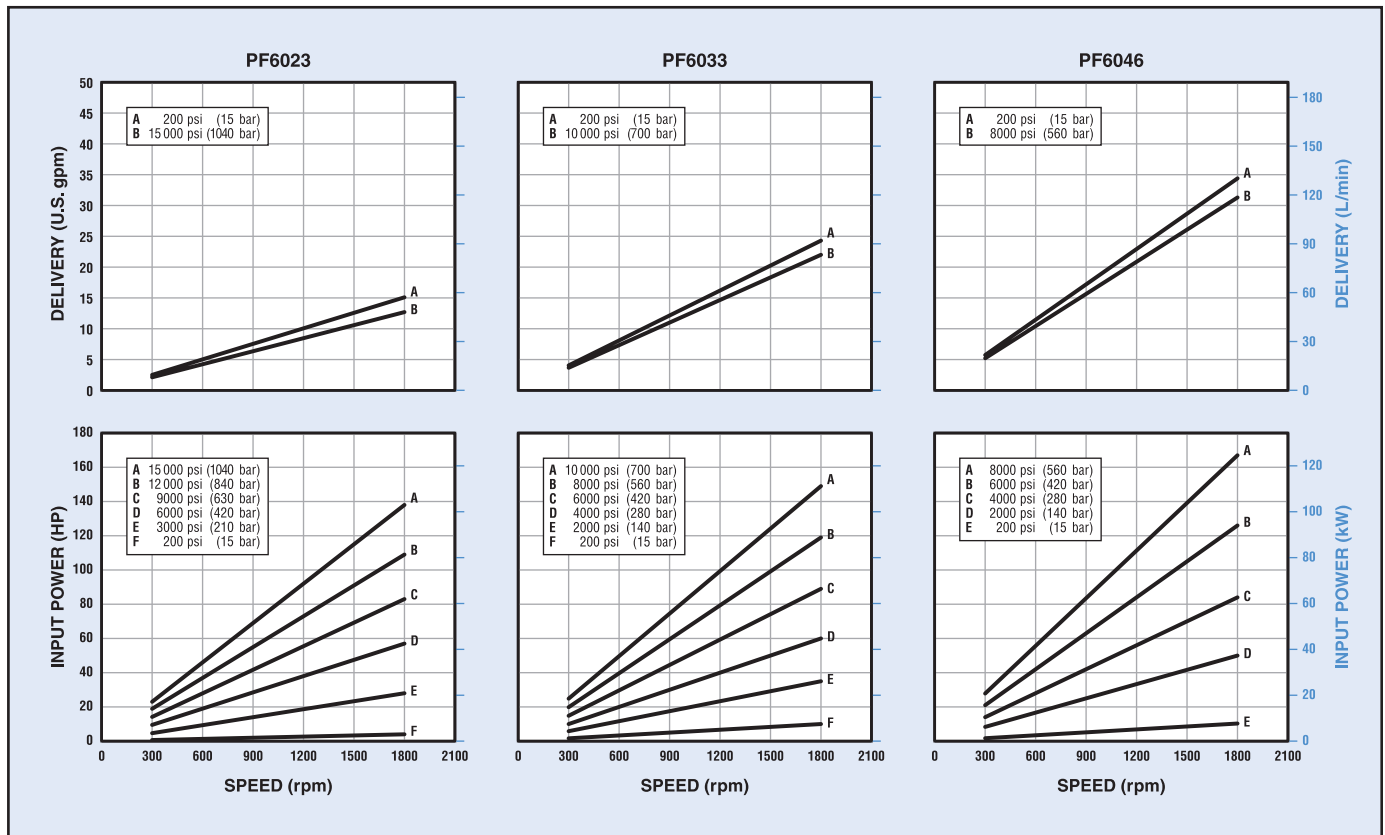

Typical performance curves are based on 100 SUS (20 cSt) mineral oil with pressurized inlet where required. Refer to the "Minimum Inlet Pressure" table on page 3.

Split-Flow® Provides Multiple Outlets

Split-Flow® models efficiently supply flows for multiple function circuits.

PF6000 Series models are available with individual piston outputs grouped together in the barrel or cover. Various piston flow splits are available in this ten-piston pump.

Models PF6033 and PF6046 are also available with isolator valves, to separate one or more pistons from the main outlet. Up to ten independent flows are possible from these ten-piston pumps. When using isolator valves, high-pressure models are limited to a maximum pressure of 6000 psi (420 bar).

Contact the Sales department for Split-Flow® options and availability.

INSTALLATION

All dimensions are shown in inches (millimeters in parentheses) and are nominal. Refer to page 5 for optional spline shaft data. Refer to [Checkball Pumps Service, Installation and Operating Instructions](#) for general installation and operating recommendations.

Minimum Inlet Pressure^①

Pump Models	Operating Speed							
	1200 rpm		1500 rpm		1800 rpm		2400 rpm	
	psi	bar	psi	bar	psi	bar	psi	bar
PF6023	0	0	5	0,4	10	0,7	–	–
PF6033	0	0	10	0,7	15	1,0	–	–
PF6046	0	0	5	0,4	10	0,7	–	–
PF6054	0	0	5	0,4	5	0,4	10	0,7
PF6070	0	0	5	0,4	10	0,7	10 ^②	0,7 ^②
PF6080	5	0,4	5	0,4	10	0,7	15 ^②	1,0 ^②

① Values shown are based on fluid viscosity of 100 SUS (20 cSt). All PF6000 Series pumps have a high-pressure shaft seal.

② Refer to maximum speeds indicated in the "Specifications" table.

Models PF6023, PF6033 and PF6046

The drawing shows dimensions common to these models. Note, however, that Model PF6023 has eight pistons, rather than ten.

As shown, the outlet port on these high-pressure models is machined in a block, which mounts axially on the pump barrel. The block is not included with the pump. A kit, which includes mounting bolts and o-rings, must be ordered separately. Refer to the table and to *Outlet Port Configurations* on page 6 to specify the port.

The drawing shows dimensions common to these three models. Note, however, the different dimensions for the outlet port and the overall length for model PF6080.

Outlet Port Block Kits

Port Type	Kit Number
<i>Model PF6023:</i>	
Coned and Threaded ^①	KP60239131
<i>Models PF6033 and PF6046:</i>	
No. 12 SAE ^②	KP60339132
Coned and Threaded ^①	KP60339133
G 3/4 (BSP) ^③	KP60339134

① High pressure outlet port uses Autoclave Medium Pressure, Butech M/P or equivalent fitting.

② Not recommended for operation above 8000 psi (560 bar). Contact the fitting manufacturer for the pressure rating of the fitting.

③ Outlet port uses British Standard Pipe Parallel fitting. Not recommended for operation above 10 000 psi (700 bar).

Models PF6054, PF6070 and PF6080

As shown, these models have an auxiliary inlet port in the cover, which provides more fluid to improve the filling of the piston pumping chambers. Use of this port will increase volumetric efficiency.

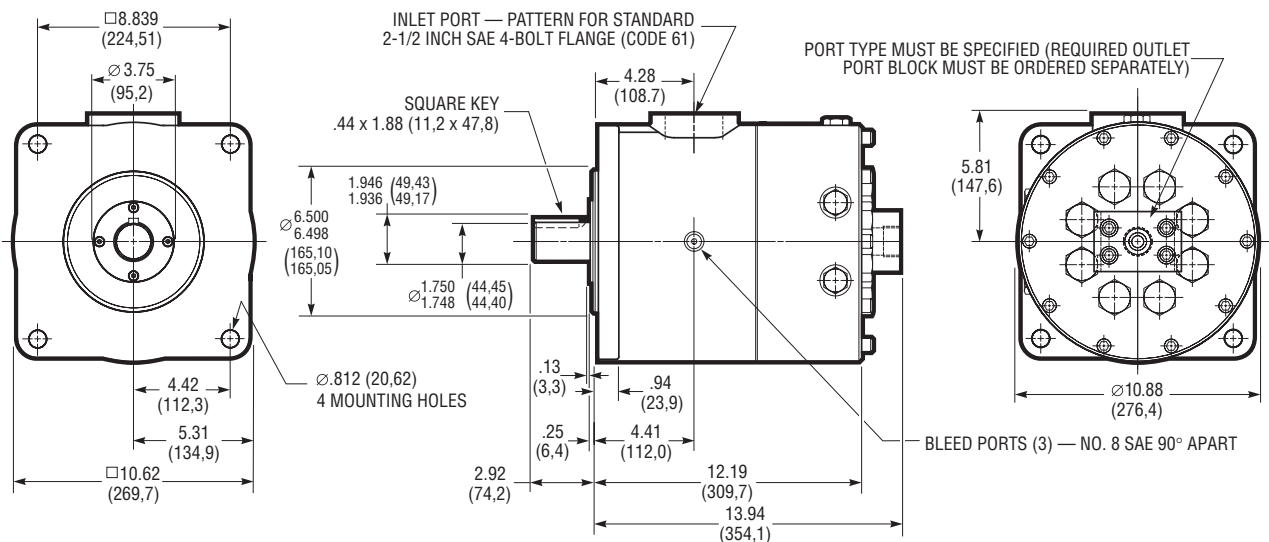

Models PF6023-3167, PF6033-3169 and PF6046-3174

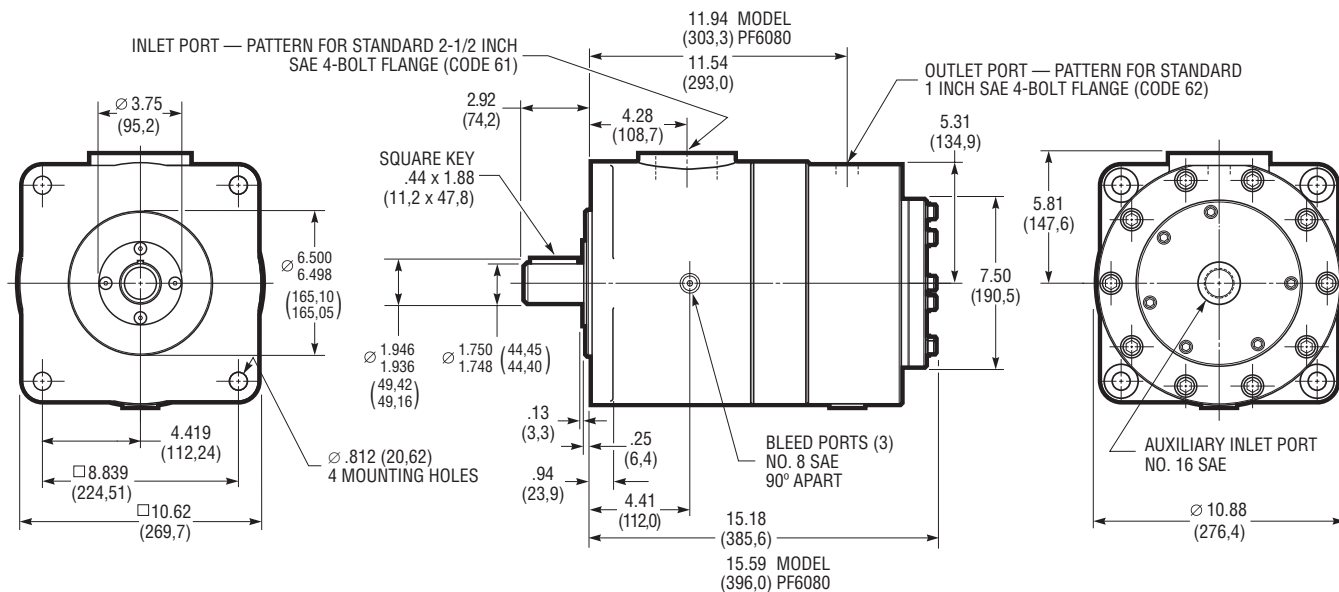

Models PF6054-2946, PF6070-3186 and PF6080-2989

Specifications shown were in effect when printed. Since errors or omissions are possible, contact your Sales representative or the Sales department for the most current specifications before ordering. Dynex reserves the right to discontinue products or change designs at any time without incurring any obligation.

www.dynexhydraulics.com

USA Headquarters

770 Capitol Drive
Pewaukee, WI 53072
Tel: +1 (262) 691-2222
FAX: +1 (262) 691-0312
sales@dynexhydraulics.com

Power Units & Systems

54 Nickerson Road
Ashland, MA 01721
Tel: +1 (508) 881-5110
ashland@dynexhydraulics.com

European Sales

Unit C5 Steel Close, Little End Road,
Eaton Socon, St Neots,
Cambs. PE19 8TT United Kingdom
Tel: +44 (0) 1480 213980 FAX: +44 (0) 1480 405662
sales@dynexhydraulics.co.uk



FLUID RECOMMENDATIONS (All Checkball Pumps)

Mineral Oil

A high-grade premium petroleum-based fluid should be used to assure long component and system life. The fluid should have a combination of anti-wear, demulsibility, rust protection, oxidation-resistant and foam-resistant properties.

Special Fluids

Various pump models are available for use with water-based fluids, diesel calibration fluids, phosphate ester fluids, machining coolant, brake fluid, various military fluids and other special fluids.

PF1300 & PF4300 Series pumps are compatible with a variety of water-based fluids. Refer to specific product documentation for specifications for these models, which are specifically rated for use with low-lubricity fluids.

Some pump models may require reduced operating pressures when using low-lubricity fluids.

Refer to separate bulletin: [Water-Based Fluid and Port Specifications](#) for use with water-based fluids.

Because of the wide range of fluid characteristics, contact the Sales department for a review of any application using non-petroleum based fluids.

Viscosity Specifications

Using fluid with the correct viscosity range is critical to achieving long component life.

Fluid conditions outside the "Optimum" range shown in the table may result in reduced pump output, requiring pressurized inlet conditions. For more information, contact the Sales department.

Hydraulic Fluid Viscosity^①

Pump Models	Operating				Start-up		Optimum	
	Minimum		Maximum		SUS	cSt	SUS	cSt
	SUS	cSt	SUS	cSt				
<i>Fixed Displacement Pumps:</i>								
PF500-20	52	8	1911	413	3706	800	98 to 324	20 to 70
PF1000-10	59	10	1911	413	3706	800	98 to 324	20 to 70
PF1300-11 ^②	–	–	–	–	–	–	–	–
PF2000-10	59	10	1911	413	1911	413	98 to 324	20 to 70
PF2000 ^③	34	2,3	1911	413	1911	413	98 to 324	20 to 70
PF3000-10	59	10	1911	413	3706	800	98 to 342	20 to 70
PF4000-30	34	2,3	1911	413	1911	413	98 to 324	20 to 70
PF4200-10	34	2,3	1911	413	1911	413	98 to 324	20 to 70
PF4300-22 ^②	–	–	–	–	–	–	–	–
PF6000	34	2,3	1911	413	1911	413	98 to 324	20 to 70
<i>Mechanical Variable Delivery Pumps:</i>								
PV4000-11	34	2,3	1911	413	1911	413	98 to 324	20 to 70
PV6000	34	2,3	1911	413	1911	413	98 to 324	20 to 70
<i>Hydraulic Variable Delivery Pumps:</i>								
PV6000	34	2,3	1911	413	1911	413	98 to 324	20 to 70

① Fluid conditions outside the "Optimum" range may result in reduced output, requiring pressurized inlet conditions. Contact the Sales department.

② Refer to separate bulletin "Water-Based Fluid and Port Specifications" for use with water-based fluids.

③ Models with special mounting.

MINIMUM FILTRATION LEVELS

Pump inlet: 150 μ nominal;

Pressure or return line: 25 μ nominal.

While finer filtration levels than these are desirable and will result in longer component life, restricting flow to the pump inlet should be avoided. Minimum recommended inlet conditions must be maintained.

If a system component fails resulting in fluid contamination, it is important to drain and clean the reservoir, all lines, filter screens and all components. Refill with new fluid.

INSTALLATION AND OPERATION

Refer to [Checkball Pumps Service, Installation and Operating Instructions](#) for general installation and operating recommendations.

That brochure includes information on mounting, shaft loading, sizing inlet pipe and hose, air bleed procedures and initial start-up. Guidelines for maintenance, repair and trouble-shooting are also included.

OUTLET PORT CONFIGURATIONS

Dynex pumps are available with outlet ports suitable for use at various pressure ranges. Refer to the appropriate *Specification Table* or *Typical Model Code* to specify the required port.

Contact the fitting manufacturer to ensure the selected fittings are rated for the maximum pump operating pressure.

SAE Straight Thread Ports

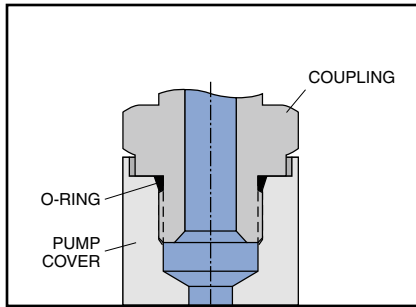

Typical SAE Straight Thread port connection

The Straight Thread connection (SAE J1926/1) is sometimes referred to as an SAE O-ring Boss, or ORB. The port consists of a machined spotface surface, a tapered seal cavity and a straight thread port.

The fitting forms a seal by compressing the o-ring in the seal cavity with the underside of the flanged wrench flat. Some adjustable fittings, such as elbows and tees, use a locknut with a captive backup washer for compression.

SAE Straight Thread ports are not recommended for operation above 8000 psi (560 bar). Also, the maximum pressure of pumps with No. 12 SAE outlet ports may be limited by the pressure rating of the available fitting. Contact the fitting manufacturer for ratings.

Coned and Threaded Ports

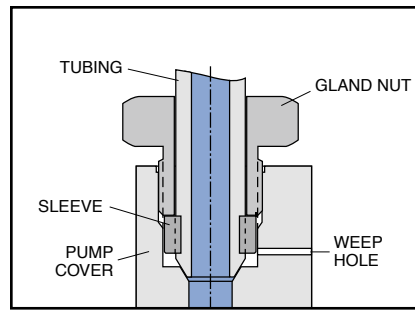

Typical Coned and Threaded port connection

High-pressure pumps are available with coned and threaded outlet ports, which use Autoclave Medium Pressure, Butech M/P, or equivalent fittings.

These fittings provide a metal-to-metal seal with an interference fit, not requiring an o-ring. The gland nut holds the sleeve and tubing against the cone surface.

A weep hole, visible on the outside of the pump cover, acts as an indicator of any abnormal leakage caused by system conditions (i.e., excessive pressure).

British Standard Pipe Parallel Ports

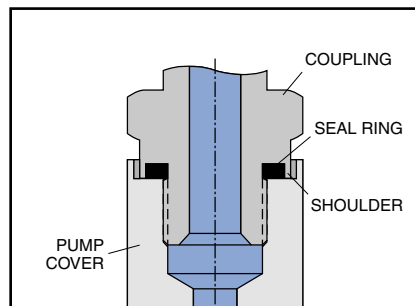

Typical British Standard Pipe (Parallel) port connection

High-pressure pumps are available with flat face ports with British Standard Pipe Parallel (BSPP) threads (BS 2779 or ISO 228), ideal for use on some European applications.

The fitting forms a seal by compressing a flat elastomer ring on a machined spotface surface. There are several sealing methods for these ports.

The recommended fitting has a recessed seal cavity formed by a shoulder on the underside of the flanged wrench flat (Voss "Peflex", Form B Shoulder Seal; or Parker Type E, "EOlastic" Seal; or equivalent).

BSPP ports are not recommended for operation above 10 000 psi (700 bar). Contact the fitting manufacturer to ensure the selected fittings are rated for the maximum pump operating pressure.

SAE 4-Bolt Flange Ports

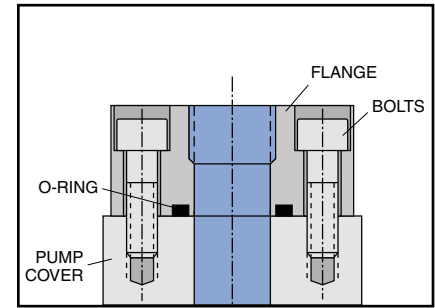

Typical SAE 4-Bolt Flange port connection

Flange connections are often used for higher flows requiring larger diameter tubing. The port consists of an unthreaded port with four bolt holes in a rectangular pattern on a machined face around the port (SAE J518).

A typical fitting consists of a flanged block with a welded tube and a captive flange with bolt holes. A seal is formed by an o-ring in the groove on the underside mounting surface of the flange head. As the flange bolts are alternately tightened, the o-ring is compressed between the flange head and the machined face on the pump.

To make mounting easier in tight spaces a two-piece split-flange is often used.